

CANDIDATE  
NAME

CENTRE  
NUMBER

--	--	--	--	--

CANDIDATE  
NUMBER

--	--	--	--

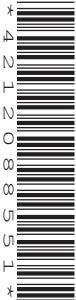

**COMPUTING**

Paper 1

**9691/12**

**May/June 2015**

**1 hour 30 minutes**

Candidates answer on the Question Paper.

No additional materials are required.

No calculators allowed.

**READ THESE INSTRUCTIONS FIRST**

Write your Centre number, candidate number and name on all the work you hand in.

Write in dark blue or black pen.

You may use an HB pencil for any diagrams, graphs or rough working.

Do not use staples, paper clips, glue or correction fluid.

**DO NOT WRITE IN ANY BARCODES.**

Answer **all** questions.

No marks will be awarded for using brand names of software packages or hardware.

At the end of the examination, fasten all your work securely together.

The number of marks is given in brackets [ ] at the end of each question or part question.

This document consists of **16** printed pages.

1 (a) A stack is initially empty.

The following sequence of operations is then performed:

Push value "Green"  
Push value "Red"  
Pop value  
Pop value  
Push value "Blue"  
Push value "Orange"

Show the contents of the stack after each operation.

[2]

(b) A queue is initially empty.

The following sequence of operations is then performed:

Insert value "Green"  
Insert value "Red"  
Remove value  
Remove value  
Insert value "Blue"  
Insert value "Orange"

Show the contents of the queue after each operation.

--	--	--	--	--

--	--	--	--	--

--	--	--	--	--

--	--	--	--	--

--	--	--	--	--

--	--	--	--	--

[2]

2 (a) Define the terms buffer and interrupt.

Buffer .....

.....

Interrupt .....

.....

[2]

(b) Describe how buffers and interrupts are used when sending data from a computer to a printer.

.....

.....

.....

.....

.....

.....

.....

.....

.....

[4]

3 Six computer terms and six descriptions are shown below.

Draw a line to link each term to its description.

Computer term	Description
Array	Removal of unnecessary data in a file by encoding it using fewer bits
Transaction processing	Software that has the ability to draw conclusions based on rules applied to stored knowledge
Data compression	System where responses to input must be quick enough to influence the source of data
Expert system	Set of elements referenced by a single identifier; each element referenced by one or more subscripts
Broadband	Volatile storage which can be written to or read from
Random access memory	Data transmission method where many channels are used at the same time; achieved by using a range of frequencies

- 4 A random access file is used to store customer records. The key field, `CustomerID`, is in the range 1000 to 9999.

A hashing algorithm has been designed to calculate each record's address using:

$$\text{Address} \leftarrow \text{CustomerID} \text{ MOD } 100$$

$x \text{ MOD } 100$  returns a value which is the remainder when  $x$  is divided by 100.

The record with this key is then stored at the calculated address.

- (a) Records with the following key fields are to be added to the file:

2003  
3097  
4007  
6098  
7008

Write the `CustomerID` where these records would be stored:

Address	Record
00	
01	
02	
03	
04	
05	
06	
07	
08	
)	)
96	
97	
98	
99	

[2]

**(b) (i)** An additional record with key field 5097 is to be stored.

State what will happen to the existing contents of the file.

.....  
.....[1]

**(ii)** Describe how the file handling software could prevent the outcome stated in **part (b)(i)**.

.....  
.....  
.....  
.....[2]

5 A nuclear power station consists of four reactors. Each reactor is monitored from a separate control room.

The monitoring system was first installed in 1995. The existing software and hardware have not significantly changed since then.

(a) The entire monitoring system is to be replaced.

Give **three** reasons why the management of the power station has decided to do this.

- 1 .....
  - .....
  - 2 .....
  - .....
  - 3 .....
  - .....
- [3]

(b) A new system has been developed. The management must choose a method of changing over to the new system when it is installed.

(i) Name and describe a suitable method of changeover.

- Name .....
  - Description .....
  - .....
  - .....
- [2]

(ii) Name and describe a method of changeover that would not be appropriate.

- Name .....
  - Description .....
  - .....
  - .....
- [2]



(c) When the monitoring system is operational, it needs to be maintained.

Describe each type of maintenance shown. Give an example which requires each type of maintenance for this system.

Corrective .....

.....

Example .....

.....

Adaptive .....

.....

Example .....

.....

Perfective .....

.....

Example .....

.....

[6]

6 The following list shows five storage media:

- CD-ROM
- DVD-RAM
- internal hard disk
- external hard disk
- flash memory

(a) The table below shows five applications.

For each application, choose the most appropriate storage medium from the list.

Application	Storage medium
A programming text book provided with sample code in electronic form	
Storage of photographs in a digital camera	
A backup of the complete PC file system; to be kept off-line	
Storage of operating system and applications software	
Simultaneous recording and playback of video files with removable optical media	

[5]

(b) (i) Name the storage medium which is an example of a solid state memory.

.....[1]

(ii) Give **two** benefits of using solid state memories.

1 .....

.....

2 .....

.....[2]

7 (a) (i) Choose between:

laser printer / inkjet printer (circle your choice)

Describe **one** feature and **one** drawback of your chosen type of printer.

Feature .....

Drawback .....

[2]

(ii) Choose between:

3D printer / graph plotter (circle your choice)

Describe **one** feature and **one** drawback of your chosen device.

Feature .....

Drawback .....

[2]

(b) Name each input device described below:

It reads parallel dark and light lines which represent a string of characters. ....

Used for entry of numbers and arithmetic symbols only. ....

Users select options by simply making finger contact with its surface. ....

It has buttons to make selections and a small wheel to allow scrolling. ....

[4]

8 (a) A student, in an electronics lesson, built the following circuit.

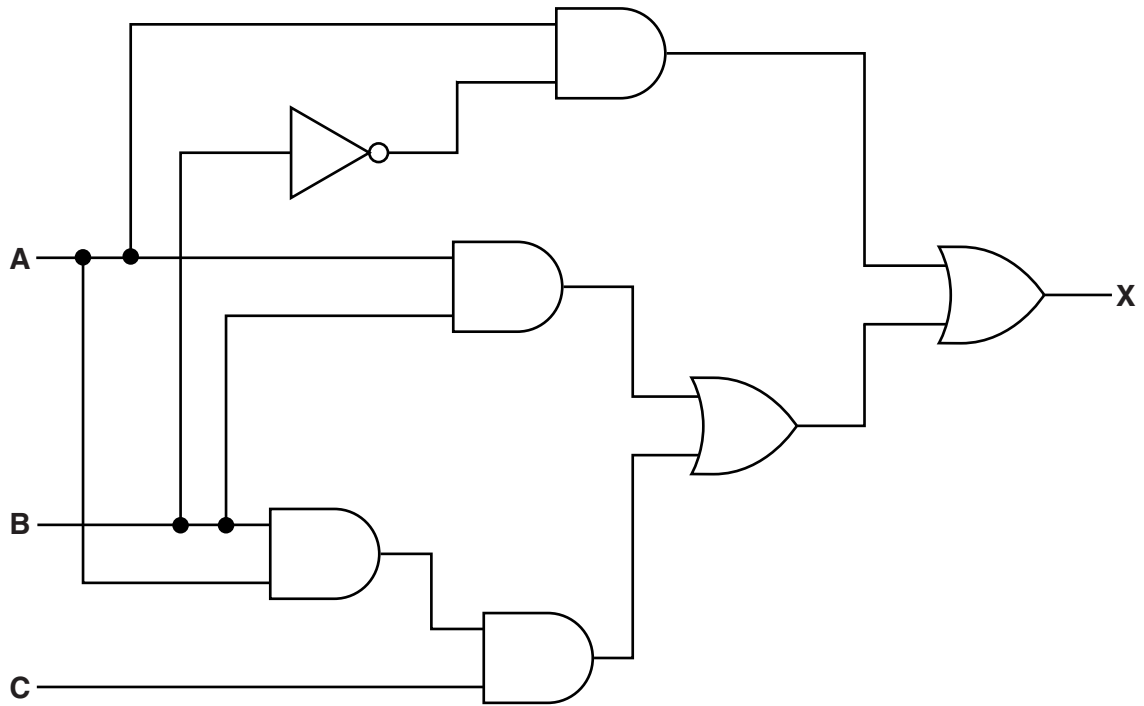

(i) Complete the truth table for this logic circuit.

Inputs			Working space	Output
A	B	C		X
0	0	0		
0	0	1		
0	1	0		
0	1	1		
1	0	0		
1	0	1		
1	1	0		
1	1	1		

[4]

(ii) Study the output in your answer to part (a)(i).

State what could replace this whole logic circuit.

.....[1]

(b) Write a logic expression to represent the following logic circuit.

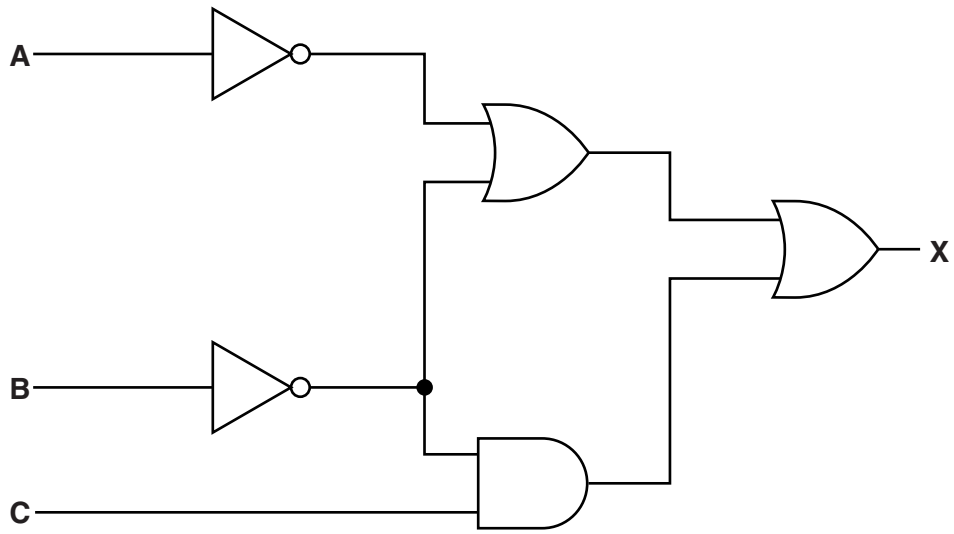

.....

.....

.....[3]

9 A college advertises its courses.

(a) Rather than advertise in a local newspaper, the college decides to produce a computer-based presentation. This presentation is to be shown in a local shopping mall.

Describe **three** advantages in doing this rather than using the local newspaper.

1 .....

2 .....

3 .....

[3]

(b) The college runs up to 30 different courses. Students can enrol online for courses.

A form has been designed to allow input of the following:

- name
- payment card number (16 digits)
- email address
- course code
- start month of course (June or November)
- agreement to college terms and conditions

### CIE College

Name:

Payment card:

Email:  @

Course code:  ▼

June  November

Agree to the terms and conditions

Study the form design.

State and justify each widget (GUI control) used. One has been done for you.

Input	Widget (GUI control)	Justification
name	text box	names can be variable lengths
payment card number	.....	..... ..... .....
email address	.....	..... ..... .....
course code	.....	..... ..... .....
start month	.....	..... ..... .....
agreement	.....	..... ..... .....
back/submit	.....	..... ..... .....

[6]

